

DOI: 10.17725/rensit.2020.12.201

On the Design of Rectenna

Mhnd Farhan

University of Baghdad, <http://www.uobaghdad.edu.iq/>
Baghdad, Iraq

E-mail: mbndfarhan@yahoo.com

Received March 04, 2020; peer reviewed March 16, 2020; accepted March 30, 2020

Abstract. This paper focuses on designing a circuit that rectifies background radiation and one that is self-biasing. This circuit set-up is called a rectenna which is a special type of antenna that is used to convert radio-frequency energy into direct current electricity. A simple model of a rectenna element consists of a monopole antenna with an radio frequency(RF) diode bridge connected in series with the antenna. The bridge rectifies the ac current induced in the antenna by the electromagnetic radiation to produce dc power which is used to bias a Bipolar Junction transistor(BJT). RF sensitive/high switching diodes are usually used because they have the lowest voltage drop and highest speed and therefore have the lowest power losses due to conduction and switching. The BJT transistor has a feedback biasing and essentially amplifies the ac signal from the antenna. The amplified signal is fed into an RF diode for dc conversion. There are two stages of amplification in order to achieve a big voltage magnitude at the output that can be used to charge a device with low power ratings. Thus the idea of a cell-less power source is achieved in such implementation.

Keywords: rectenna; cell-less power source; design

UDC 621.396.6

For citation: Mhnd Farhan. On the Design of Rectenna. *RENSIT*, 2020, 12(2):201-206; DOI: 10.17725/rensit.2020.12.201.

CONTENTS

1. INTRODUCTION (201)
 2. SYSTEM DESIGN(202)
 - 2.1 THEORY OF OPERATION (203)
 - 2.2 ACTUAL DESIGN (204)
 3. RESULTS AND ANALYSIS (205)
 - 3.1. INCIDENT POWER AND VOLTAGE ANALYSIS (205)
 - 3.2. INPUT AND OUTPUT VOLTAGE ANALYSIS (205)
 - 3.3. VOLTAGE-CURRENT CHARACTERISTICS (205)
 4. CONCLUSION (206)
- REFERENCES (206)

1. INTRODUCTION

Background radiation is electromagnetic radiation due to mobile telephone systems and broadcasting in transmission of information. This electromagnetic energy can be converted to electrical energy and used to power electrical devices.

Conversion to electrical energy is effected by

use of a rectenna. A rectenna or a rectifying antenna is a special type of antenna that is used to convert radio frequency (RF) energy into direct current electricity. They are used in wireless power transmission systems that transmit power by radio waves. A simple rectenna element consists of a monopole/dipole antenna with an RF diode connected across the monopole/dipole elements. The diode rectifies the ac current induced in the antenna by the microwaves, to produce dc power, which powers a load connected across the diode. Large rectennas consist of an array of many such dipole elements [1,2].

The research in rectennas is diversified whereby different types of rectennas perform differently to achieve the same objectives. These include RF rectenna and optical rectennas.

With optical rectennas, it has been theorized that similar devices, scaled down to the proportions used in nanotechnology, could be used to convert light into electricity at greater efficiencies than

what is currently possible with solar cells.

Theoretically, high efficiencies can be maintained as the device shrinks, but experiments have so far only obtained roughly 1% efficiency while using infrared light.

Essentially, the use of batteries as energy source can be eliminated by using wireless powering. Besides recharging an integral battery is no more necessary for continuous telemetry operation. Depending on the power consumption requirement of a device or system, wireless remote powering can be performed with either near-field inductive coupling or far-field electromagnetic coupling. The choice of the remote powering frequency is based on the constraints of the application such as power consumption, device size, read range or proximity, transmission medium and data rate. This improvised system of device charging is what is ideally referred to as a cell-less power source. While a high data rate and high read range make it necessary to use high frequency communication, higher power delivery makes the use of near field powering more preferable. However the methodology in this paper implements far field powering [3,4].

A method to justify the above problem is the design of an antenna for its target integrated rectifier for far-field electromagnetic energy. Harvesting is done by use of RF antenna for pick-up power where the energy signal from the electromagnetic radiation is fed into the rectifier.

However, unavoidable process variations cause different input impedances and efficiency performances depending on the process corner of the fabricated chip.

The above methodology can be implemented with an addition of npn transistor and high switching diode. This enables amplification of the input ac signal from the antenna and the amplified signal is converted to dc by the diode to obtain a reasonable output. Therefore

dual stage amplification is necessary to obtain a bigger magnitude output[5,6].

2. SYSTEM DESIGN

The most suitable choice for implementation is the design of a monopole antenna used with a rectifier built with well-characterized commercially available rectifier. This enables us to evaluate the performance of the rectenna more accurately, in order to achieve a reasonable overall efficiency and a good conversion efficiency at the incident frequency.

This rectenna uses monopole antenna principle, which feeds an RF diode quad bridge. The bridge is capable of handling high frequencies where FR207 diodes (RF sensitive/high switching) are used.

This rectenna element operates efficiently at much lower incident power levels of 20–65 mW with little reflected RF power (i.e., the overall efficiency is 1% lower than the conversion efficiency). This characteristic has two important applications in microwave-power beaming systems:

1. Power can be converted efficiently at the edge of the rectenna where power densities are lower than the center elements.
2. Power can be converted efficiently when the transmission distance is large and power density is low

2.1 THEORY OF OPERATION

The circuit shown in **Fig. 1** is modified and additional components added whereby a monopole antenna attaches to a quad bridge, which transforms the monopole impedance to

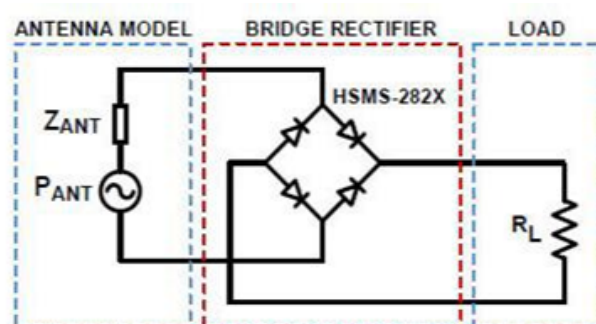

Fig. 1. The main components of the rectenna element.

the bridge impedance and rejects higher order diode harmonics from radiating through the monopole.

In order to ensure that the source and rectifier impedance are matched for obtaining correct input impedance of the rectifier, we use the built-in optimizer of Advanced Design System(ADS). It minimizes the reflection coefficient between the source and the load which therefore maximizes by finding conjugate input impedance with the given input power. **Fig. 2** shows simulation results of the input impedance of the rectifier versus frequency for 6 dBm of input power. Each point of the curve corresponds to matched source impedance as determined by the optimizer.

Suppose that the target input power is 6 dBm for the selected rectifier. Assuming the rectifier impedance $Z_{RECT} = 11.7 - 108 \Omega$ by calculation. Maximum power transmission condition states that the rectifier and antenna have conjugately matched impedances. Therefore the target antenna impedance is determined as $Z_{ANT} = 11.7 + 108 \Omega$.

The maximum simulated gain of the antenna is found as -5.1 dB and input impedance of the antenna is found as $Z_{ANT} = 11.7 + 108 \Omega$. The antenna having dimensions of $12\text{mm} \times 10\text{mm}$ with dielectric thickness of 0.5 mm is fabricated on Rogers RO4003C dielectric with $(\epsilon_r = 3.55)$.

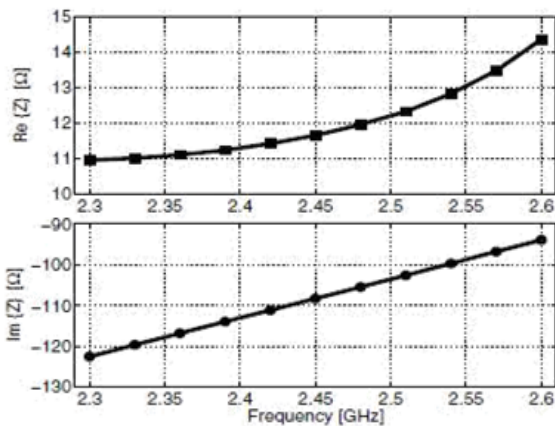

Fig. 2. Simulation results of the input impedance of the rectifier.

The typical operation of a rectenna element can be better understood by analyzing the bridge’s dc characteristics with an impressed RF signal.

This simple model as illustrated in Fig.1 assumes that the harmonic impedances seen by the diode are either infinite or zero to avoid power loss by the harmonics. Thus, the fundamental voltage wave is not corrupted by higher order harmonic components.

The rectenna conversion efficiency then depends only on the diode (bridge) electrical parameters and the circuit losses at the fundamental frequency and dc.

Fig. 3 shows the equivalent circuit of the diode used for the derivation of the mathematical model. The diode parasitic reactive elements are not included in the equivalent circuit. Instead, it is assumed they belong to the rectenna’s environment circuit.

The environment circuit is defined as the circuit around the diode that consists of linear-circuit elements.

The diode model consists of a series resistance R_s , a nonlinear junction resistance R_j described by its dc IV characteristics, and a nonlinear junction capacitance C_j . A dc load resistor is connected in parallel to the diode along a dc path represented by a dotted line to complete the dc circuit. The junction resistance R_j is assumed to be zero for forward bias and infinite for reverse bias.

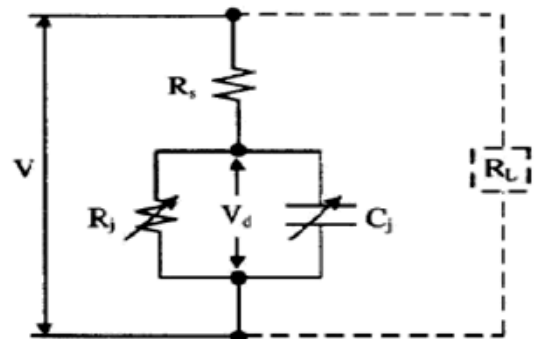

Fig. 3. Equivalent circuit model of the rectifying circuit.

2.2 ACTUAL DESIGN

Fig. 4 is an illustration of a self-biasing circuit adopted from the simulation and a graph demonstrating a dc output voltage.

With the incident input power ranging from 20-65 mw, the antenna produces approximately 4.03 v and current of 10.7 mA which is got from the relation $P = V^2/R$ where R is the intrinsic impedance (120π) with incident power of 43 mw (16.33 dBm). The antenna in the circuit diagram is represented by a power source.

The monopole antenna is adjusted accordingly to give the maximum pick-up power. With a pick-up test done using a radio, it is observed that the best operating frequency is at 100.3 MHz. From the relation $c = f\lambda$, the wavelength is calculated to be 3 m. From the monopole antenna characteristics, the wavelength is $\lambda/4$ which is approximately 0.75 m (75 mm) and thus the antenna is adjusted to this length to give maximum efficiency.

At the rectifier stage, RF sensitive diodes (FR207) are used which are sensitive to high frequencies ranging from 85 MHz to 110 MHz and thus ac signal from the antenna is rectified to dc signal and obtained at the output of the bridge. This dc signal is just sufficient to bias a bipolar junction npn transistor to its quiescent point.

The transistor is set-up in the feed-back/

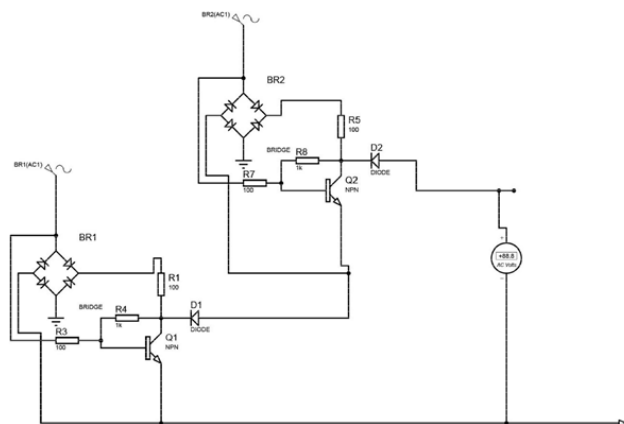

Fig. 4. Circuit diagram of the design implementation from simulation.

self-biasing configuration. This self-biasing configuration is another Beta(β) dependent biasing method that requires only two resistors to bias the transistor. The collector to base feedback configuration ensures that the transistor is always biased in the active region regardless of the value of Beta (β) as the base bias is derived from the collector voltage.

In this circuit, the base bias resistor (RB) is connected to the transistors collector, instead of to the supply voltage rail (Vcc). Now if the collector current increases, the collector voltage drops, reducing the base drive and thereby automatically reducing the collector current. Then this method of biasing produces negative feedback.

The biasing voltage is derived from the voltage drop across the load resistor (RL). So if the load current increases there will be a larger voltage drop across RL, and a corresponding reduced collector voltage (VC) which will cause a corresponding drop in the base current (IB) which in turn, brings (IC) back to normal.

The opposite reaction will also occur when transistors collector current becomes less. Then this method of biasing is called self-biasing with the transistors stability using this type of feedback bias network being generally good for most amplifier designs.

With this configuration, the transistor essentially amplifies the ac signal from the antenna and has a feedback factor/gain of 10. The feedback path also provides the system with stability. With the amplified output obtained from the transistor element; it passes through a diode to convert to dc.

There are two stages of amplification in the above setup, each with equal parameters set whereby the output of the first stage is fed into the second stage for further amplification. The combined output magnitude of the two stages is further amplified using an operational amplifier with a feedback factor/gain of 10 to achieve a

reasonable magnitude of 5.3 V that can be fed into a device charging systems rated at 5 V-10 V. When a 370 Ω load is put across the output terminals, a reasonable current of 200 mA is achieved at the output of the operational amplifier.

3. RESULTS AND ANALYSIS

3.1. INCIDENT POWER AND VOLTAGE ANALYSIS

With the input power range already known to be 20-65 mW, a relation of incident antenna power in free space to voltage is established. A graph of varying input power level density in milliwatts with voltage (V) at intrinsic impedance is plotted as shown in Fig. 5.

The above relationship demonstrates that voltage input increases with increasing power density which implies that the antenna should be adjusted such that it receives optimal power and thus obtain maximum conversion efficiency. The differences between the overall efficiency and conversion efficiency indicate that little power (< 1%) is reflected.

3.2. INPUT AND OUTPUT VOLTAGE ANALYSIS

With the varying input voltages, a relation is drawn with the output of the dual amplification level at 1millisecond of simulation as shown in Fig. 6.

The above behavior is observed demonstrating some erraticism and showing that the output power levels vary with minor disparities. These minor disparities occur at the expected input

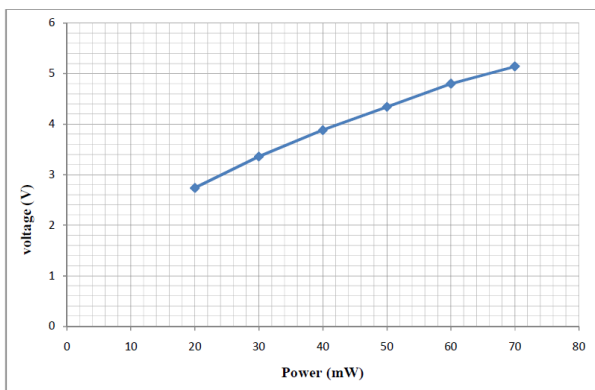

Fig. 5. Incident antenna power versus voltage.

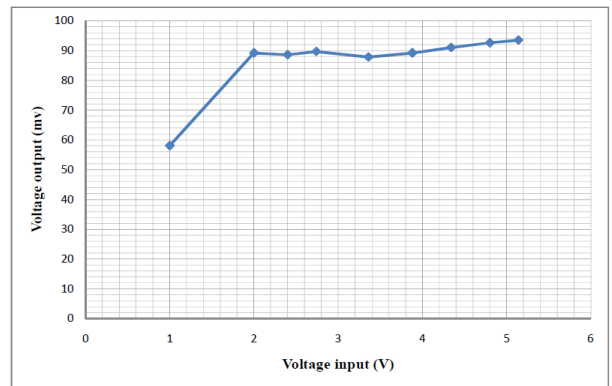

Fig. 6. Input and output voltage analysis.

voltage range (2.7-5) V. The disparities could be credited to the fact there are losses in the input power due to mismatch between the rectifier and the antenna. Assuming minimal mismatch losses in the rectenna design, the conversion efficiency of the diode is limited primarily by the rectifying diode. As such recommendations towards determining ways of increasing the conversion efficiency of the diode other than through the change of load resistance is beneficial.

3.3. VOLTAGE-CURRENT CHARACTERISTICS

Fig. 7 demonstrates ohms law showing that the simulation is accurate with the results obtained when a load of 200 Ω is connected across the output terminals.

However this observation implies that with a fixed load at the output, the variation of electromagnetic radiation could alter the current value at the output causing a spike or a value which is lower than the rating. With the use of a

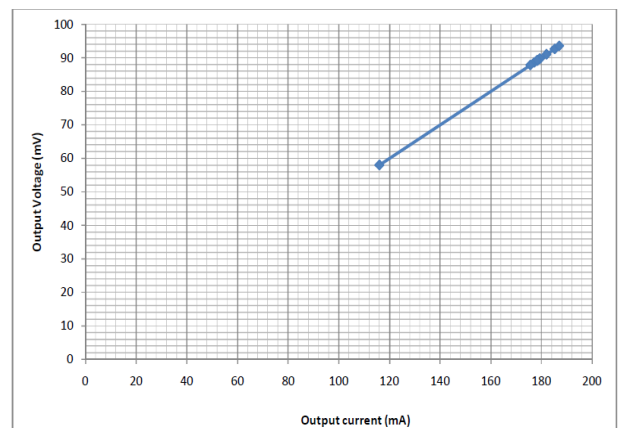

Fig. 7. Voltage-current characteristics.

regulator, the output can be stabilized although this doesn't control the input power density.

The breakdown voltage of the diode limits the power handling capability of each rectifying circuit. The diode model needs to be valid for a wide range of biasing in order not to affect the output voltage. This will in turn ensure the current at the load is not affected and the system therefore operates successfully.

4. CONCLUSION

The work in this paper was mainly implemented through a run simulation and the results obtained were reasonable in contrast with practical realization of previously done implementations.. The objectives of the experiment were achieved whereby self-biasing circuit was created and produced output that can be used to charge a device with a rating of at least 5 V. The antenna allows 100 MHz operating frequency to pass and diodes used prevent interference of signals and re-radiation of higher order harmonics generated due to the RF sensitivity and high switching property.

REFERENCES

1. J. Shin, M. Seo, and J. Choi. A compact and wideband circularly polarized rectenna with high efficiency at X-band. *Progress In Electromagnetics Research*, 2014, 145:163-173.
2. C. Song, Y. Huang, J. Zhang, and S. Yuan. A high-efficiency broadband rectenna for ambient wireless energy harvesting. *IEEE Transactions on Antennas and Propagation*, 2015, 63(8):3486-3495.
3. H. Mei, X. Yang, B. Han, and G. Tan. High-efficiency microstrip rectenna for microwave power transmission at Ka band with low cost. *IET Microwaves Antennas & Propagation*, 2016, 10(15):1648-1655.
4. H. Sun, and G. Wen. A new rectenna using beamwidth-enhanced antenna array for RF power harvesting applications. *IEEE Antennas & Wireless Propagation Letters*, 2016, 16:1451-1454.
5. D. Gretskih, A.V. Gomozov, V.A. Katrich.

Mathematical model of large rectenna arrays for wireless energy transfer. *Progress In Electromagnetics Research*, 2017, 74:77-91.

6. Y. Shi. Design of a novel compact and efficient rectenna for WiFi energy harvesting. *Progress In Electromagnetics Research C*, 2018, 83:57-70.